

SG 6293

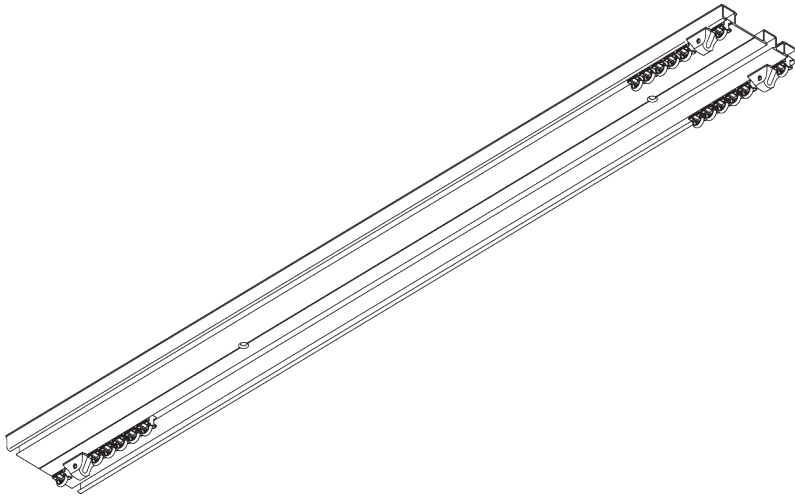
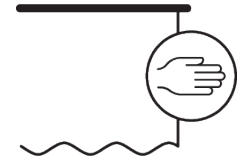

PRODUCT INFORMATION

- **Operation:** hand
- **Range:** M - L
- **Fitting:** ceiling
- **Colours:** white RAL 9016; special colours or anodised aluminum possible
- **Fabrics:** refer to Silent Gliss fabric collection

Features:

- 2-component (2C) glider technology
- Pre-drilled profile

SYSTEM SPECIFICATIONS

A. PROFILE

Profile information

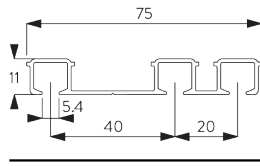

SG 6293p
Profile

B. HOW TO MEASURE

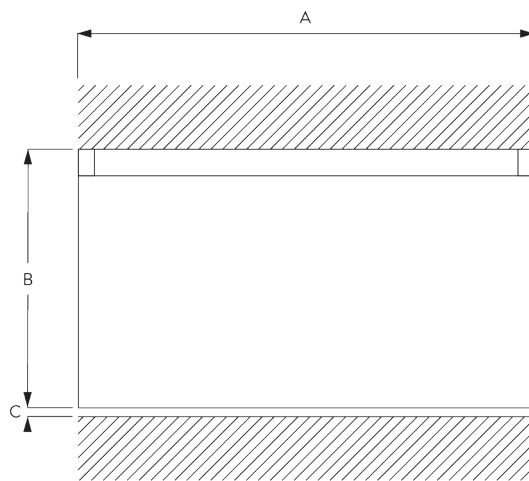

A: System width
B: System height
C: Distance between floor and fabric

C. SPECIFICATION

TEXT

Silent Gliss SG 6293 Hand Operated Curtain Track System. Comprises aluminium profile SG 6293p supplied made to measure powder coated white, 2C gliders 11300 at 14/m and 2 end stops SG 6065 per length. Top fixed direct through track profile.

FITTING

A. FITTING INFORMATION

Fixing points

For detailed fitting information, visit the [Silent Gliss website](#).

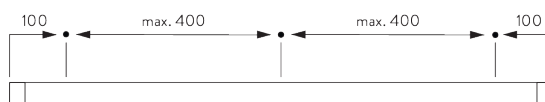

B. CEILING FITTING

Direct fitting

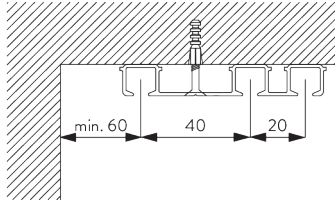

PARTS

A. STANDARD PARTS



SG 6065

End stop



SG 6283

Roller



SG 6293p

Profile



SG 11300

2C glider

B. OPTIONAL PARTS



SG 3582

Hook



SG 3599

Hook



SG 6053

Spring stop



SG 6094

Roller



SG 6098

Roller

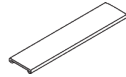

SG 6269

Connection bridge



SG 6283

Roller



SG 10430

Draw rod 50 cm

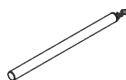

SG 10431

Draw rod 75 cm

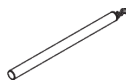

SG 10432

Draw rod 100 cm

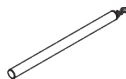

SG 10433

Draw rod 125 cm

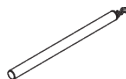

SG 10434

Draw rod 150 cm

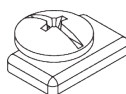

SG 11295

End stop



SG 11301

2C glider on strip